

To support Audio Video system integration to/from remote cameras. The Cat5 RemoteCam1 module has been developed. This allows an interface over a single Cat5 cable for convenient, cost effective remote mounting of PTZ cameras. Regulated camera power, control and video are carried on a single standard Cat5 UTP wire for distances up to 300'.

The Cat5 RemoteCam1 is designed to integrate with:

Canon	VC-C4
Elmo	PTC-100S
Sony	EVI-D100/70

SCT part number: RemoteCam1 1 (for the remote camera interface package)

Included in this package are:

1. Mounting Bracket: This bracket mounts to a standard 2-gang wall box for clean, convenient mounting of the camera. Typical electrical boxes would be:
 - a. new construction 2-gang switch box
 - b. "mud" box
 - c. old work (retrofit) boxes.
2. Mounting Screw: A thumb screw is provided for attaching the camera to the mounting bracket shelf.
3. Interface Modules: This pair of interfaces provides composite video, power and 4-wire (RX, TX, GND plus IR) control for the camera. One small electronics enclosure is required at the rack or head end and a second module is mounted to the back of the camera mounting plate, housed in the 2-gang box.
4. Power Supply: The included 30VDC power supply is designed to operate the camera up to 300' from the head-end while providing clean, regulated power for safe operation of the camera. The 30 volts from the power supply is regulated to 12 VDC at the camera for clean, reliable operation.
5. **Cable Set**: Provided with the package is a custom cable set that includes:
 - a. Power Patch Cable (remote module to camera)
 - b. Camera Control Patch Cable (8-Pin mini Din to remote module)
 - c. Video Patch Cable (camera video output to remote module)
 - d. Video Cable (for the head end)
 - e. Format Converter High quality, passive, bi-directional Composite > S-Video format converter

Simple Signal Flow:

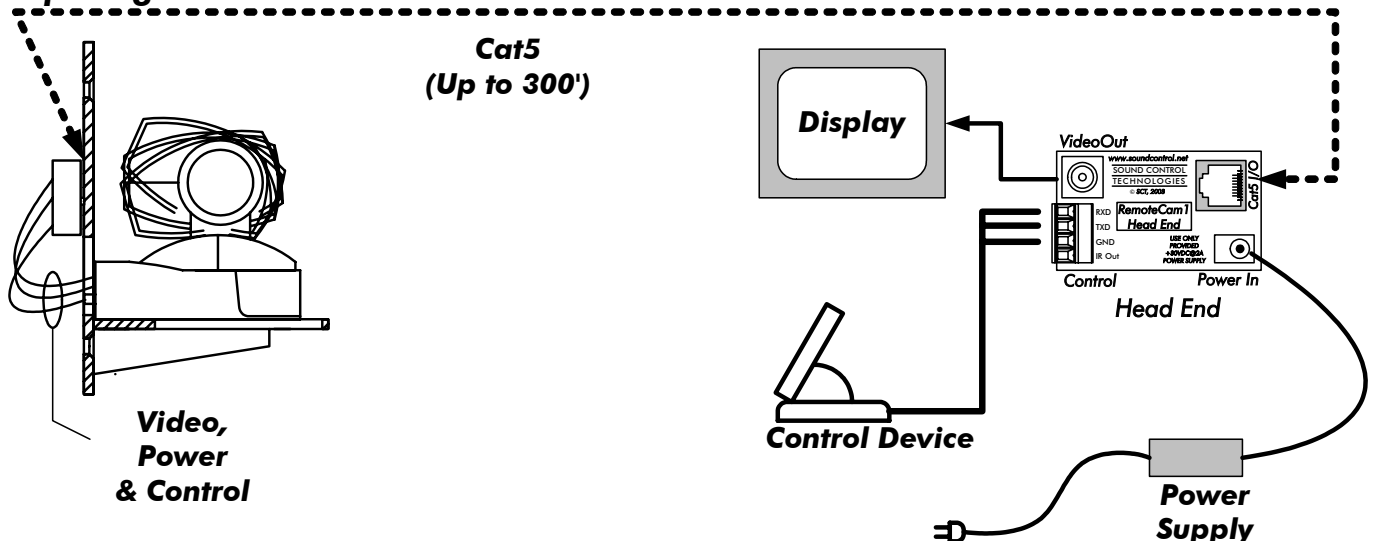

Profile of camera mounted on wall bracket

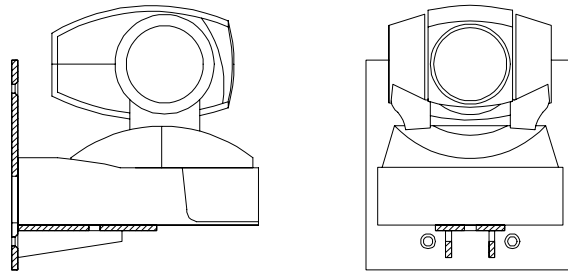

Camera bracket mounting details:

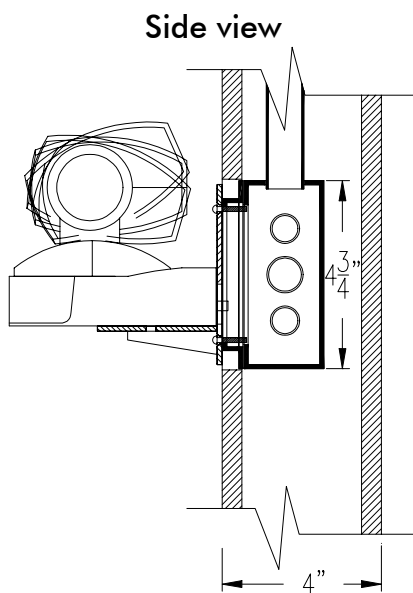

Camera wall-mount bracket

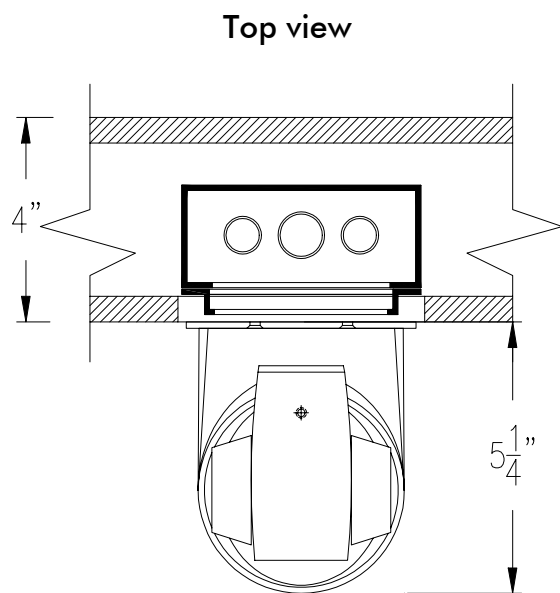

Head End module

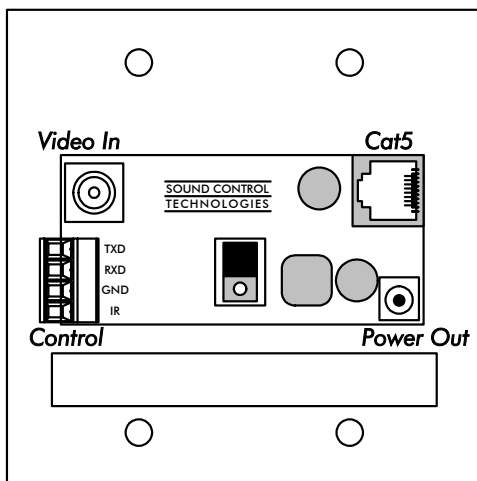

Camera End

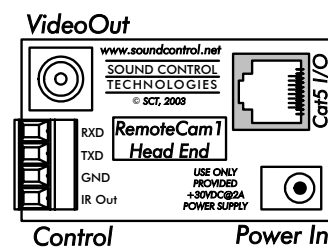

Head End

Physical control wiring for the RemoteCam 1 and a PC serial port:

Please note that PC serial port wiring and remote control system wiring may differ slightly. The following wiring has been tested to support individual manufacturers programming and control software applications.

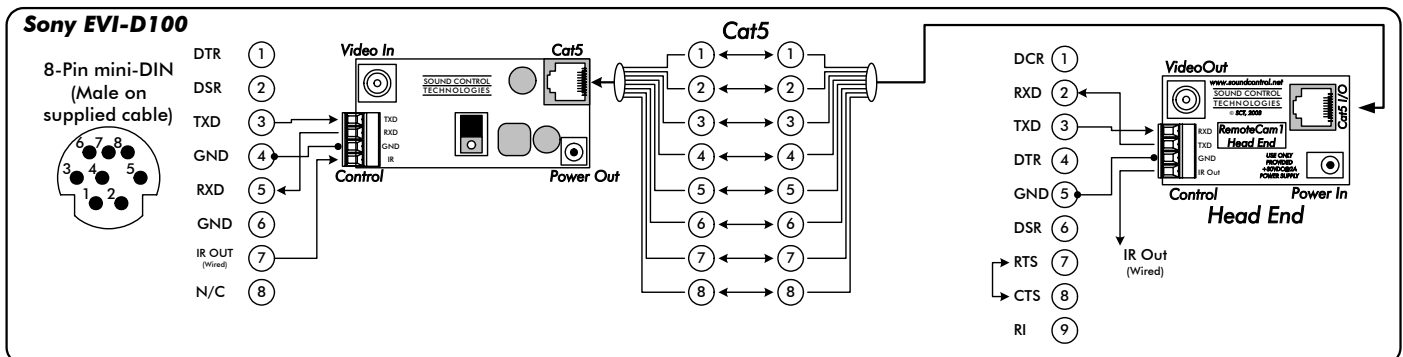
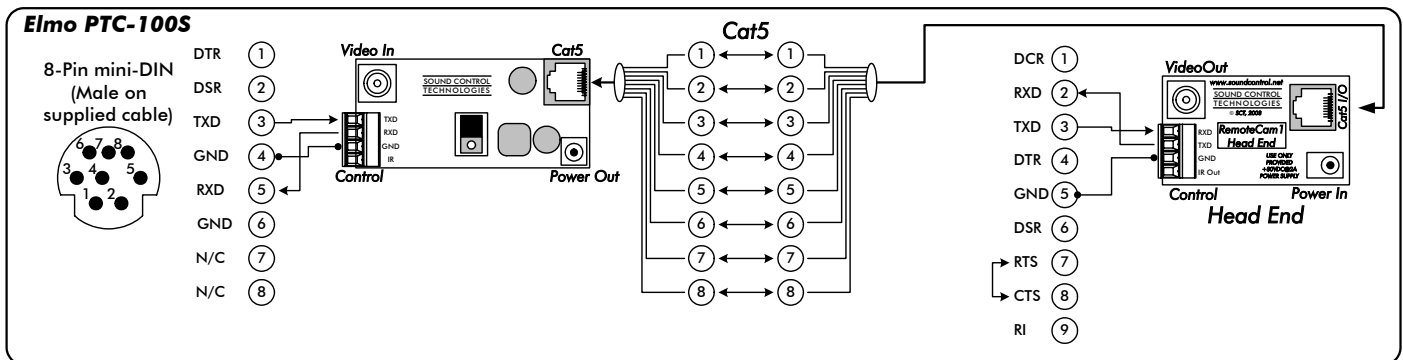
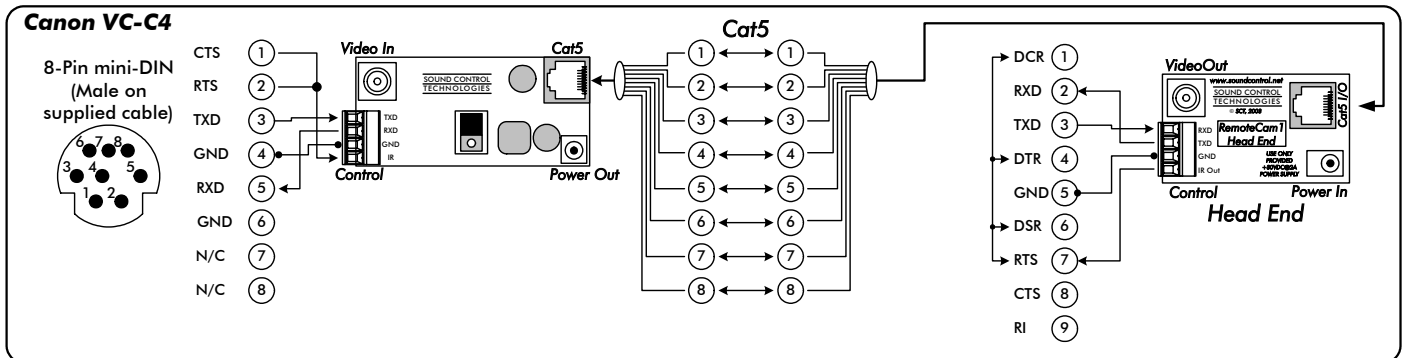

* Please note that all references to IR wiring are for "wired" IR at TTL logic level (5V).

SOUND CONTROL TECHNOLOGIES

CAT5 REMOTE CAM 1 OVERVIEW & INSTALLATION GUIDELINES

Camera Control Pin-outs

8-PIN MINI DIN	CANON VC-C4	ELMO PTC-100S	SONY EVI-D100
Pin 1	CTS	DTR	DTR
Pin 2	RTS	DSR	DSR
Pin 3	TXD	TXD	TXD
Pin 4	GND	GND	GND
Pin 5	RXD	RXD	RXD
Pin 6	GND	GND	GND
Pin 7	N/C	N/C	IR Out
Pin 8	N/C	N/C	N/C

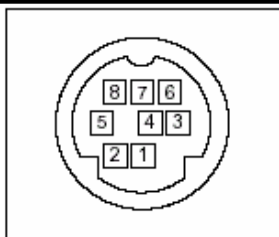

Camera 8-Pin mini-Din
RS-232 In (Female)

Wiring of the modules:

CAMERA	CAMERA MODULE	CAT5	HEAD END MODULE	PC SERIAL PORT
CANON VC-C4				
3 (TXD)	1	TX>RX	1	2 (RXD)
5 (RXD)	2	RX<TX	2	3 (TXD)
4 (GND)	3	GND	3	5 (GND)
1-2 (CTS/RTS)	4	CTL	4	8 (CTS)
ELMO PTC-100S				
3 (TXD)	1	TX>RX	1	2 (RXD)
5 (RXD)	2	RX<TX	2	3 (TXD)
4 (GND)	3	GND	3	5 (GND)
N/C	4	-	4	N/C
SONY EVI-D100				
3 (TXD)	1	TX>RX	1	2 (RXD)
5 (RXD)	2	RX<TX	2	3 (TXD)
4 (GND)	3	GND	3	5 (GND)
7 (IR Out)	4	IR	4	IR Out

Technical Specifications:

Technical specifications are subject to change. This information applies to a product under development, specifications are subject to change without notice.

Camera Interface:

Video Input: _____ Analog Composite
Control RS-232 I/O 4-wire (RX, TX, GND) & IR In
Power Output +12VDC @ 1.3A Max

Head-End Interface:

Video Output: _____ Analog Composite
Control RS-232 I/O 4-wire (RX, TX, GND) & IR Out
Power Input +30VDC @ 2.0A Max

Video Connections: _____ "RCA" Type Connectors

Power Connection: _____ 2 Pin Mini Captive wire Connector

Power Requirements: _____ +30VDC, 2.0A
External Plug-In, Universal AC Input Supply Included

Size: _____ H 0.75", W 1.5", D 2.5"

Weight: _____ 1.0 lbs.

For the original equipment supplier, custom configurations of the Series II ASP-8X8 AUDIO MATRIX™, Acoustic Echo Cancellation, Microphone Mixers, Camera Control Products and other SCT equipment are available. Please contact SCT for details on pricing and availability.

www.soundcontrol.net

28 Knight Street, Norwalk, CT., 06851

© SOUND CONTROL TECHNOLOGIES, INC., 2003 - 2004

Page 4 of 4

Phone (203) 854-5701 Fax (203) 854-5702

CIM_05c.Doc-8/25/2004