



Supporting the Cisco SpeakerTrack 60 and Cisco Codec Plus, SX80, C40, C60 & C90

### TEST YOUR LINK CABLE

We highly recommend using an Ethernet Network Tester/Analyzer alongside our provided PowerSniffer to confirm your LINK cable's wiring. Our PowerSniffer only tests conductor continuity and will not identify data integrity or capacity issues.

1. Test and verify your CAT6 LINK cable for UTP 568A/568B. Link cable must be between 30ft - 300ft.
2. Connect the provided PowerSniffer to the SpeakerTrack end of your Cat6 Link cable.
3. Connect the other end of the Link cable to the LINK connection on the Head End module.
4. Connect the WPS-48 power supply to the Head End module.
5. Connect the WPS-48 power supply to AC mains.
6. If the SCT Link cable is properly terminated, it will display eight GREEN LEDs.  
If you get any other result, **stop and re-terminate cable**.
7. Once your cable has been tested, please disconnect the WPS-48 power supply from the RC6-HE module, and the PowerSniffer from the LINK cable, before proceeding to install.

### INSTALL THE EXTENSION KIT

Before integrating your RC6-CST kit, please ensure your Cisco SpeakerTrack base is connected to your two Cisco Precision 60 cameras (Power and Ethernet connections) via Cisco's instructions.

#### Connect the camera-end cables:

1. Connect the first RCC-C011 video cable between the RC6-CE's HDMI connector labeled "HDMI INPUT 1" and the first camera's HDMI connector. The 270° HDMI end will connect to the RC6-CE.
2. Connect the second RCC-C011 video cable between the RC6-CE's HDMI connector labeled "HDMI INPUT 2" and the second camera's HDMI connector. The 270° HDMI end will connect to the RC6-CE.
3. Connect the first RCC-H016 control cable between the RC6-CE's RJ45 connector labeled "Ethernet" and the SpeakerTrack's rightmost RJ45 connector.
4. Connect the PPC-010M power cable between the RC6-CE's power output labeled "12VDC Output" and the SpeakerTrack's power input.

#### Connect the codec-end cables:

5. Connect the second RCC-H016 cable between the Cisco SX80's RJ45 control connector and the RC6-HE's RJ45 connector labeled 'Ethernet 1'.
6. Connect the first RCC-H001 cable between the codec's HDMI connector and one of the two HDMI outputs labeled "HDMI OUT 1".
7. Connect the second RCC-H001 cable between the codec's second HDMI connector and one of the two RC6-HE's HDMI connectors labeled "HDMI OUT 2".
8. Connect one end of your Cat6 LINK cable to the RC6-HE module's "SCT Link" port. Connect the other end to the RC6-CE module's "SCT Link" port.
9. Connect the WPS-48 Power Supply to the "DC 48V In" jack on the RC6-HE Module.

• ALLOW UP TO TWO MINUTES FOR THE SPEAKERTRACK SYSTEM TO INITIALIZE •

**Installation Status** - Refer to our modules' LEDs for installation status.

For assistance troubleshooting INACTIVE LED statuses, please contact Tech Support at 203-854-5701.

MODULE	LED LABEL	ACTIVE STATUS
RC6-CE	OK LED	Blinking Green (-1 second interval)
RC6-HE	OK LED	Blinking Green (-1 second interval)
RC6-HE	LINK LED	Solid Blue
RC6-HE	HDCP LED	Blinking Green (-0.5 second interval)

**Cable Table** - Part numbers, descriptions and functions of all SCT cables provided for the RC6-CST. This kit is also inclusive of **[2] mount ears** for the Camera End module and **[1] RC-RK6/7 Rack Shelf**.

CABLE	DESCRIPTION	FUNCTION
RCC-C011 (x2)	3' 270° HDMI Cable	Video connection between camera pair and RC6-CE.
PPC-010M	1' Power Cable	Supplies power from RC6-CE to SpeakerTrack base.
RCC-H001 (x2)	3' HDMI Cables	Dual-video connection between RC6-HE and codec.
RCC-H016 (x2)	3' RJ45 to RJ45	Control connection between RC6-HE and codec. Control connection between SpeakerTrack and RC6-CE.

**Power Supply Specifications (AC-Mains Side):** Input Voltage: 100VAC to 240VAC 47Hz to 63Hz. Efficiency: 85% minimum. Turn-on Surge: Less than 60 amperes for a duration less than 1mS. Power Factor: 0.9 minimum (where applicable). 48VDC power supply uses 2.80 amperes AC maximum. All specifications subject to change without notice.

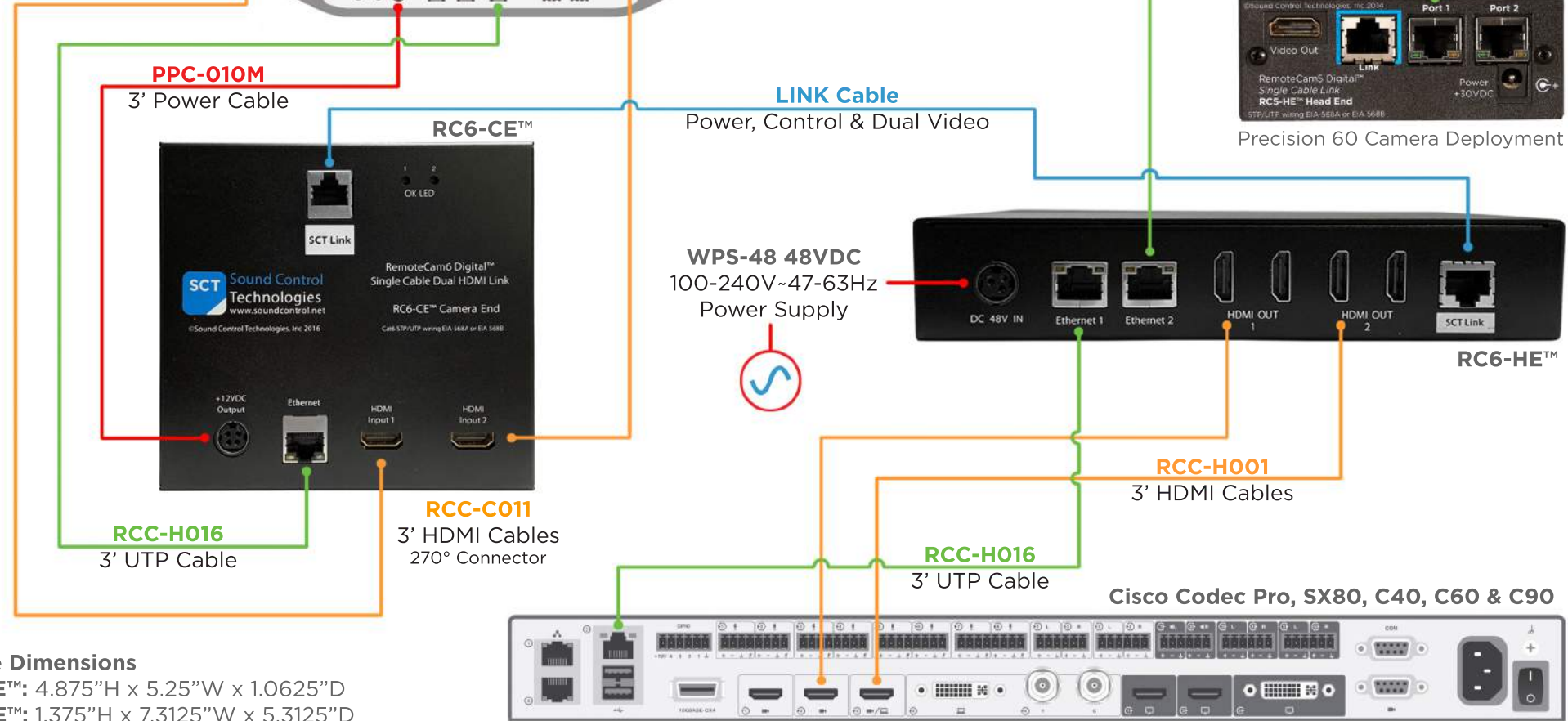

**LINK Cable Specs**

Integrator-Supplied CAT6 STP Cable  
EIA568A or EIA568B (Min. 30' to 300' Max)

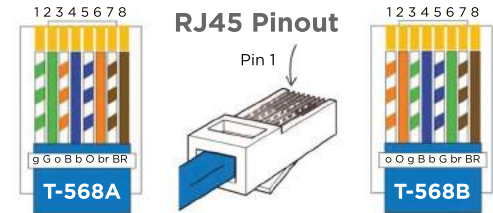

**Module Dimensions**

**RC6-CE™:** 4.875"H x 5.25"W x 1.0625"D

**RC6-HE™:** 1.375"H x 7.3125"W x 5.3125"D